

# The Garage Door Manual for Architects and Builders



What Every Architect And Home Builder Should Know  
About Residential Garages And Garage Doors ! .....  
..... but didn't know whom to ask.



Manual Stock Code:- MAN 14 Vers 1

Includes a question and answer exchange between :-  
Mr. Archie Tect, ( an architect ),  
Mr. Bill Durr, ( a developer / builder ), and  
Mr. Gar Agedor, ( Professional Door and Operator Installer ).

Important facts and technical information for  
Architects, Quantity Surveyors and Builders.

*" pro-alpha 2000" and "Aladdin"*  
*Advanced Technology Garage Door Operators.*  
*" branodor" Hardware and Doors.*

# Garage Designs

## A Garage Is A Garage ! ..... or Is It ???

Gar Agedor :- "When I tell you that 90% of my installation problems are induced by architects and builders, I am not exaggerating. Or that inconsiderate design and almost total disregard for standards costs your clients, the poor unsuspecting homeowner, an absolute fortune for no justifiable reason, would you believe me?"

Archie Tect :- "In what way are we creating problems or incurring unnecessary costs for our clients?"

Bill Durr :- "I just build according to the plans, why point a finger at me?"

Archie Tect :- "And I have to make do with the space available. I can't do more than that! Besides, the garage is only for parking cars in, it's not a place for human habitation."

Gar Agedor :- "Wrong !!! For most people, their motor car is the most expensive purchase they make after their home, and it is the one thing they will lavish the most attention on after their family. Indeed, the motor car is often regarded as a member of the family. So the garage is used for family habitation!

Besides that, to be serious, the garage is now such an integral part of the home environment, it cannot be regarded as merely a place to park the car in.

Archie Tect :- "Please elaborate!"

Gar Agedor :- "Security is a major concern for all of us nowadays. The one time and place we are vulnerable is when we are entering or leaving our homes. No one wants to be exposed for longer than is necessary. Getting out of the car to open and close gates and doors is no longer acceptable to most people. Automatic garage doors and gates are no longer regarded as luxuries ... they are now essential security items!" The problem starts when architects and builders do not make provision for the installation of security equipment, especially automatic garage doors. You design and build a garage of some sort and leave it up to the homeowner to sort out any problems there may be on his own. Most home buyers are not expert in these matters and do not know what to specify or ask for. It is up to the architect to advise and guide the homeowner in these matters! I have often had to make special doors for clients which cost 2 to 3 times more than a standard door in order to satisfy the homeowner's desire to have an automatic door. Just a little forethought on the part of the architect, and builder, would have saved the client several thousand rands, and me a lot of headaches.

Archie Tect :- "But surely all you do is manufacture a door to suit whatever size opening is built".

Gar Agedor :- I recall three cases in particular in which I was involved which were particularly frustrating for me and the client. All the houses were in the multi-million Rand bracket! The first was a double storey house in Sandown, Sandton. A very exclusive area!

The garage was big, 3 cars wide and 3 - 4 metres deeper than a standard garage. There were beams running from front to back as well as transversely across the garage. The highest portion of the ceiling was 2700 mm above the floor, but the beams extended down from the ceiling to be flush with the underside of the lintel. Effectively, there was no headroom available for the door and operator to fit into. The client had wanted a top-of-the-range automatic timber garage door. As he drove a Range Rover, it was necessary for the door to clear the full height of a standard size opening, (2135 mm), to allow the vehicle through.

The ideal door for this application was a Sectional type door! There was no possible way to install such a door in the garage! In fact there was no garage door that could be used other than a horizontal sliding gate running on the outside of the structure. The whole appearance of the house was spoiled.

I was present on site when the owner confronted the architect about the problem. This was in the early 1980's and automatic garage doors were not the norm at the time, but the client had informed the architect of his desire to have one. He asked the architect why he had not taken the requirements of the door into account. The architect replied that the operational requirements of garage doors had been a secondary consideration when designing the garage. The support of the upper floors had taken priority and he had not been aware of the type of vehicles being used. He had assumed that the door manufacturer would make the door "to suit" the structure. The owner replied.... "Are you telling me that after spending R 3 million on this house I will still have to get out of my car to open the garage door?" ... and then punched the architect right in the face".

Archie Tect :- "You're kidding me".

Gar Agedor :- "I'll give you the name and address. Then there was a huge multi-million Rand house in Randburg with twin double size doors, (an 8 car garage). The nibs were circular in shape and the thatched roof rose at a 45 - 50 degree angle to a height of nearly 10 metres. No provision had been made to support the door mechanism and operator. Fixing the tracks to the nibs was difficult as there was no "flat" area to fix to and the architect would also not allow us to install any supports which would hang from the rafters as this would spoil the "openness of the design". The nibs were over 4 metres wide, and this prevented us from supporting the tracks from the side walls. We were expected to install the door without any visible supports. The doors and operators were expected to "levitate in defiance of gravity".

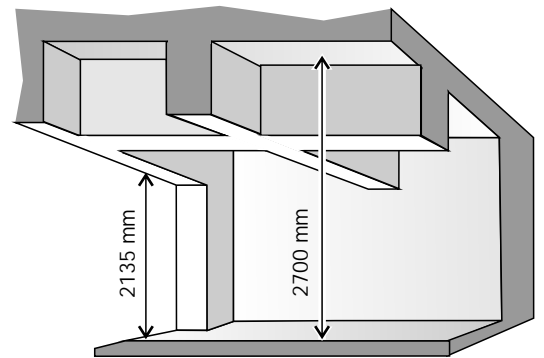
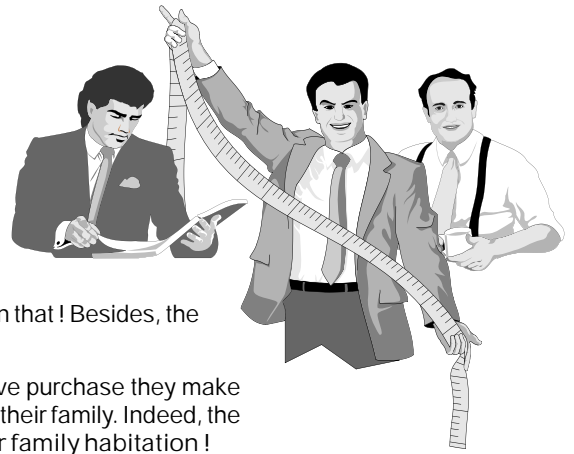

Section Through Garage Showing Positions of Internal Obstructions

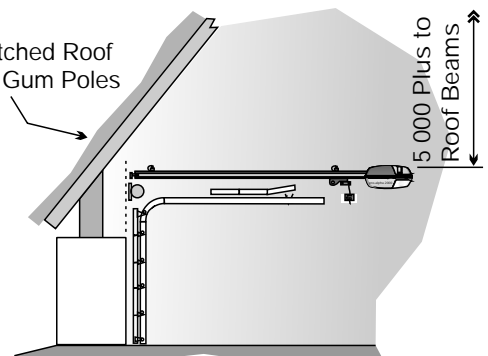

No structure to attach door hardware and operator to.

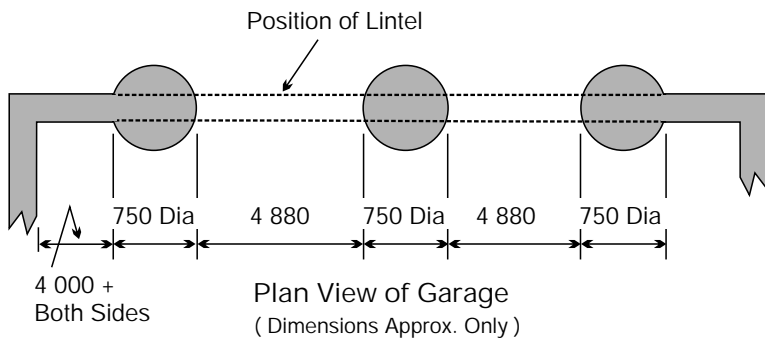

Fortunately, for me, the property owner, understood the problems we faced and instructed the builder to install beams that we could use for supports in the appropriate places. He informed me some months later that he had deducted the extra costs incurred from the architect's fee" and re-imbursed me for the extra time and materials we had used.

Bill Durr :- "I must admit that I have seen similar cases, but in all my experience, they were architect induced problems".

Gar Agedor :- "Allow me to burst your bubble. The other multi-million Rand house I'll tell you about was in Roodepoort. It was built for a well known Springbok Rugby player. It was a 3 storey structure. The garages were properly designed with plenty of headroom, nib-space and back-space. Unbeknownst to the architect, the builder skimped on the floor structure.

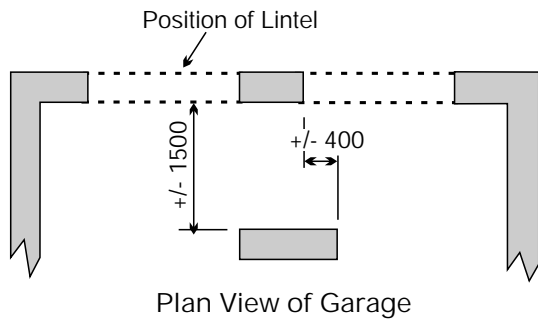

By the time the upper structure was completed, the ceiling of the garage started to sag alarmingly. At the centre of the span, the ceiling had sagged about 100 mm or more ! The architect authorised the builder to erect a supporting column in the centre of the garage. By the time the column was completed, it was so big that it encroached into the vehicle path by over 400 mm, right where the driver's door would be. It was not possible for the driver to get out of his car through the driver's side door. He had to access the car through the passenger side door !!! I remember the site meeting very well.

Mr. B. senior put his hand on my shoulder and suggested that it would be best if I left the meeting as he did not want me to witness scenes of violence that might scar me psychologically for life. A couple of weeks or so later when I returned to install the garage doors and operators, the column was gone, and so too were the architect and builder.

I never did find out if they had survived the meeting and I was too afraid to ask. I did a lot of work for Mr. B. senior for many years after that. I can relate a dozen more such stories, but I have made my point !

Archie Tect :- "What do we need to know?"

Gar Agedor :- "It's quite simple really! Modern garage doors of the "overhead" type, especially those that will be automated need space in which to operate. The more ... the better !!! I will give you the minimum space required for a "standard" installation, but first, let me describe the 3 main types of doors used in domestic installations throughout the world.

Bill Durr :- "Please bear in mind that we always have budget constraints when we build. Not everyone can afford or even wants an automatic garage door".

Gar Agedor :- "Granted ! But it does not cost very much to make provision for automatic doors. Some people, like it or not, are forced to install them. If they are injured or become incapacitated, an automatic door will probably become a necessity. Also, people move house ! The next owner may want one. Why make it difficult for them to change the doors.

I do not believe that the cost to you to provide for the option is really that great, besides, the client pays for it !

### 3 Popular Types of Residential Garage Doors

#### 1/ Sectional Type Doors:-

Without doubt the best type of garage door available. No other door type can compare with this door. It is superior to anything else on the market ! The Sectional Door can easily be made to suit any size or shape of opening, from single width to double and even triple width openings. It can easily be made to accommodate door heights up to 10 metres and more. "Daylight" openings can be square, rectangular, arched or any other shape desired. The door comprises a number of sections which are hinged together and which run on rollers in a guide track. When automated, this is the safest, most reliable and most secure door there is .... period !! It is also an easy door to service and repair ! It's one disadvantage .... it is the most expensive type of door available !

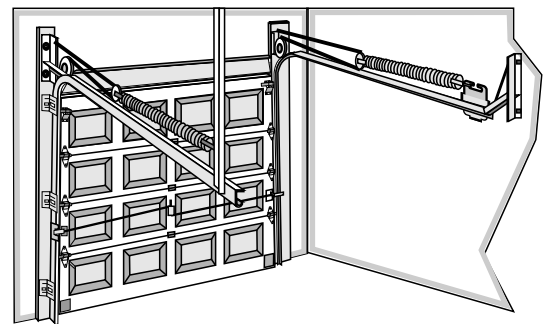

#### 2/ "One-piece" Tip-Up Type Doors:-

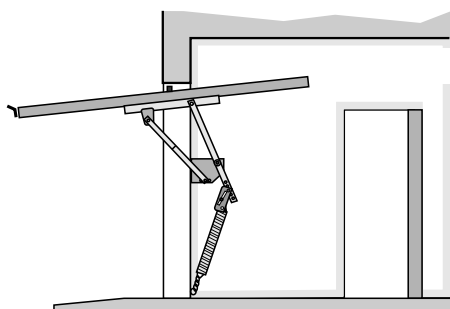

Until a few years ago, a very popular type of door for domestic applications. The emergence of the sectional type door has relegated the Tip-Up type door to the garage door museum. In the USA, for example, this type of door now has less than 10 % of the market share and probably less than 20% in South Africa and reducing.

The door passes through the opening as it moves and when fully opened is partially inside and partially outside of the garage. Whilst cheaper than the "sectional" type door, the "one-piece" Tip-Up door has one major disadvantage ..... it can only be used in openings which are square or rectangular in shape. No "arched" openings allowed !!!

It also reduces to usable opening height by up to 150 mm which rules it out of contention for garages used by 4 x 4 vehicles.

### 3/ Steel Roll-Up Type Doors:-

A low price has ensured the popularity of this type of door. Whilst it can be used for a wide variety of opening shapes, there are limits to the size of opening that can be covered! Also, automation of this type of door requires some special adaptor kits and installation techniques. Automation of a Steel Roll-Up door is more expensive than that for a Sectional Door and often costs more than the door itself.

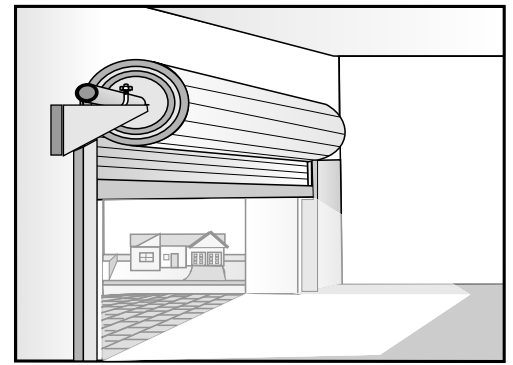

### Notes On Construction Of Garages

- 1) In the garage door industry, garage doors are always identified according to their position as viewed from inside of the garage.
- 2) All dimensions in mm.
- 3) Construct accurately. Sizes given are "finished sizes", i.e. plaster and skreed work is completed.

### The Most Important Clearances.

"Without doubt, the two most important sizes to keep in mind when designing garages is the headroom and backspace. Without sufficient headroom and backspace, the installation of "overhead" type garage doors is compromised and may even be impossible in some cases. All Tip-Up and Sectional doors are "overhead" type doors! Here are the minimum clearances recommended for automatic garage doors. As stated before, always provide sufficient space for "automatic" doors, even though they may not be required or desired initially. You can never be sure that one day they will in fact become essential!

### Avoid Unnecessary Problems

For your convenience, a number of typical "problem" garages are shown and categorised. Use these drawings to explain exactly what types of problems have to be considered when designing the door / door hardware / automation system.

Builders employ many innovative ways to save on building costs. This is commendable, especially if the benefits are passed on the owner. When constructing a simple garage, these savings can amount to several hundred Rands. The cost of making a door which will accommodate these cost saving designs and have it work as it should, can amount to several thousands of Rands!!! Here are some real humdingers that door installers just hate!!! Please avoid such problems! As the Architect / Builder, you are in the best position to avoid such problems. Door installers don't have such opportunities! We have to "fix-up" what others have "messed up"!

### SABS 60335 Part 2 - 1995 and Amendments

This standard deals with the automation of garage doors, gates and window blinds / shutters.

It sets down the operational parameters and the minimum safety requirements which must be complied with.

As the primary specifier of products used in the construction and finishing of residential and commercial properties, architects, quantity surveyors and builders should be aware of and become intimately knowledgeable with these standards. The way in which the law now protects the consumer in South Africa is such that the burden of responsibility for the adequate protection of the consumer falls upon the specifier / purchaser / supplier / installer in that order. It is therefore in the interest of all concerned that everyone in the construction and door industries be made aware of these standards and implement them without delay.

## How Much "Working Space" Is Really Needed ?

Gar Agedor :- Here are the important dimensions you should design and build to:-

### " Working Space" For One-piece Tip-up Doors

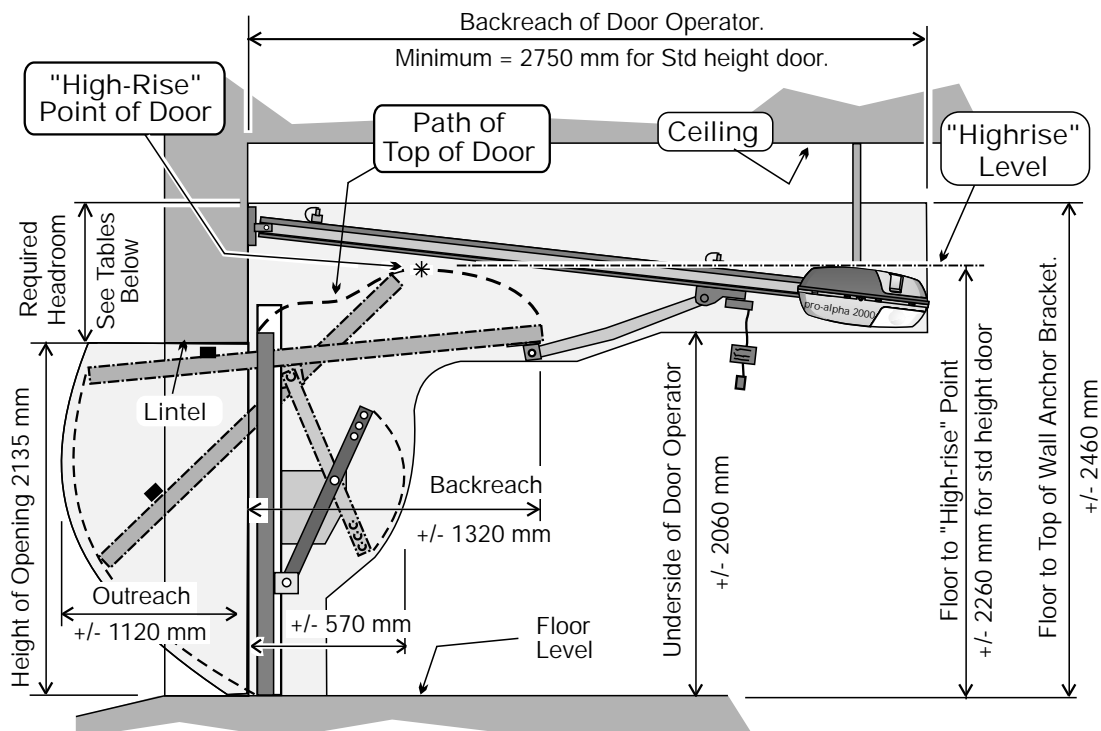

# "Working Space" Required for Standard Size Sectional Doors

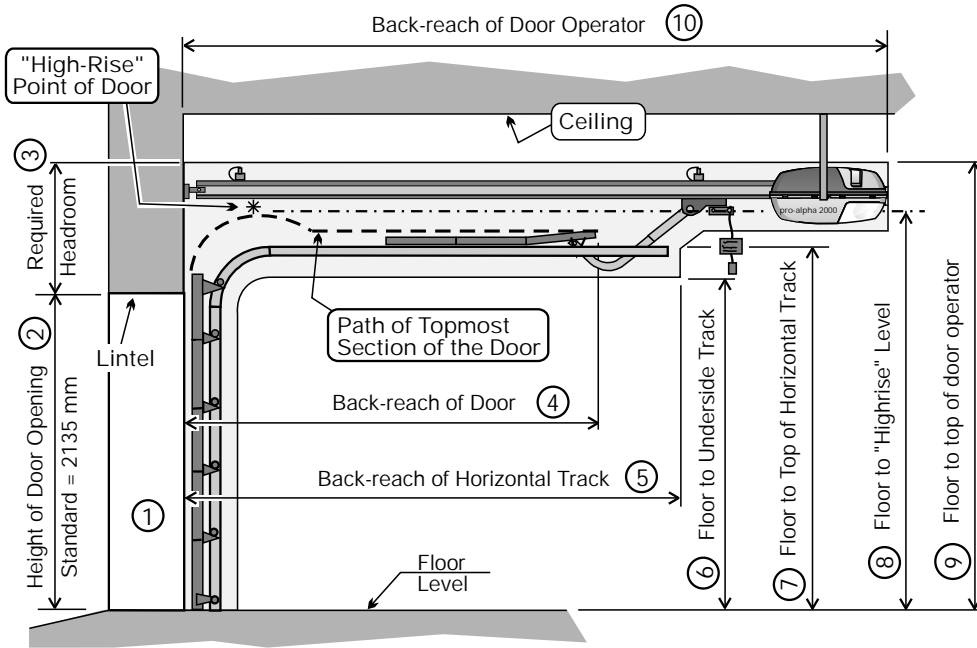

All dimensions in mm

Opening Width (1)	Opening Height (2)	No. of Sect.	Track Radius	Minimum Manual	Headroom (3) Automatic	Back-reach Door (4)	Back-reach Track (5)	Floor - to - Track U/side(6)	Track Top (7)	Highrise Level (8)	Top of GDO (9)	Back-reach GDO (10)
Standard Height Doors - 4 and 5 Sections												
2440	2135	4	380 (15")	365	440	2220	2600	2300	2355	2500	2575	3100
2440	2135	5	305 (12")	285	360	2220	2600	2225	2275	2420	2500	3100
4880	2135	4	380 (15")	365	440	2220	2600	2300	2355	2500	2575	3100
4880	2135	5	305 (12")	285	360	2220	2600	2220	2275	2420	2500	3100
Caravan Height Doors - 5 and 6 Sections												
2440	2630	5	380 (15")	365	440	2665	2900	2800	2855	2925	3070	3800
2440	2550	6	305 (12")	290	360	2665	2900	2640	2695	2840	2910	3800
4880	2630	5	380 (15")	365	440	2665	2900	2800	2855	2925	3070	3800
4880	2550	6	305 (12")	290	360	2665	2900	2640	2695	2840	2910	3800

## Internal "Working Space" for Automated Overhead Type Garage Doors

The sketch at right shows the internal "Working Space" required by overhead type residential garage doors and door operators. Important Note :- Make sure that access doors will not be fouled by the door mechanisms.

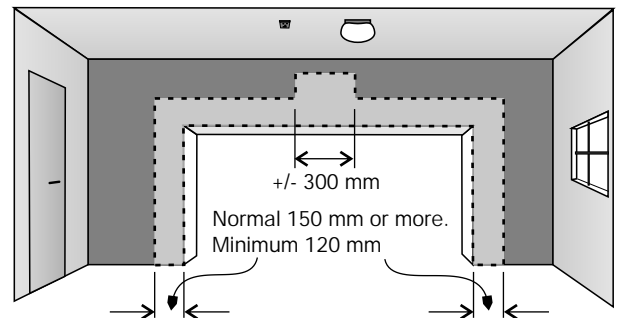

## "Working Space" For Steel Roll-up Doors

Space Required for Standard Size Steel Roll-Up Doors

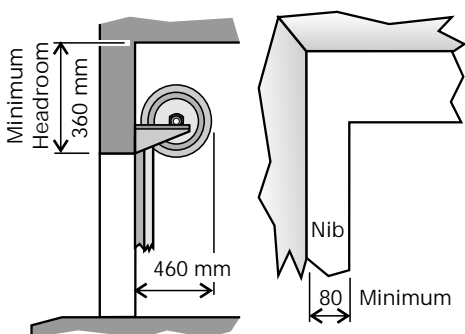

Minimum Space Required for Installation of a Standard "pro-rola" System

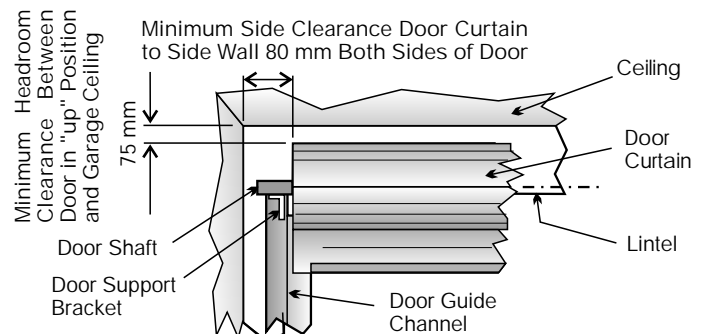

# The Ideal Garage Structure.

## Type 1 Garage Structure

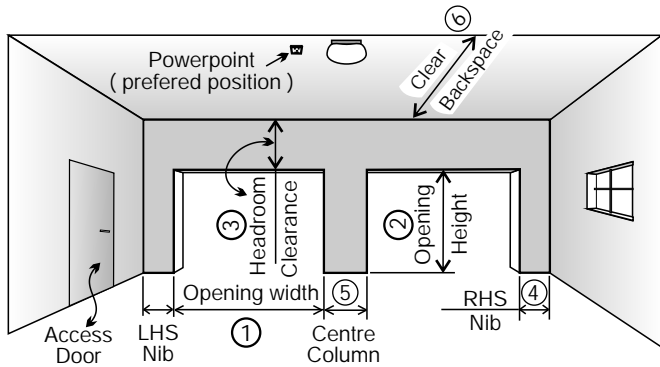

Typical Garage Design  
(with 2 single size doors)

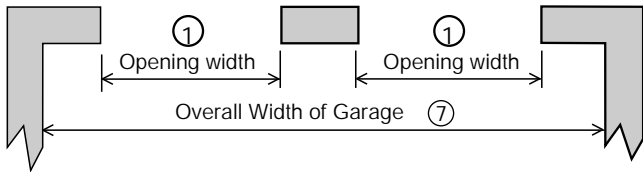

Plan View of Garage

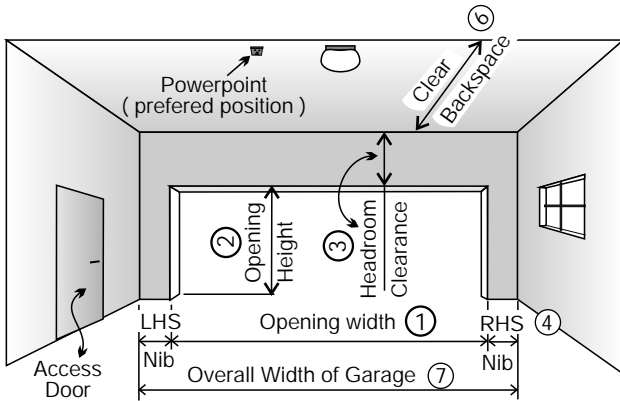

Typical Garage Design  
(with 1 double size door)

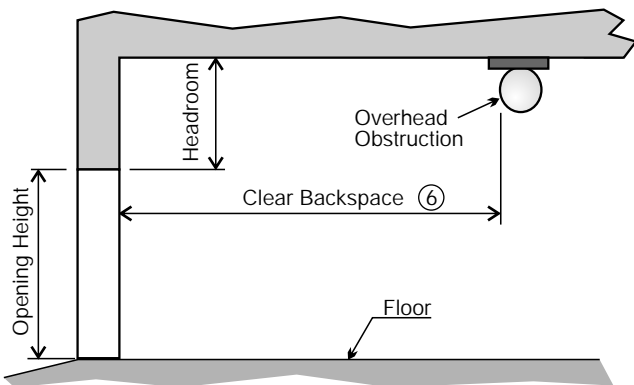

Cross-Section Through Garage

### Important Notes:-

The table below shows the recommended and absolute minimum amount of "Working Space" that is required for the normal installation of standard size Sectional doors. If the space available is less than that stated here, then special equipment will be required to undertake the installation.

The "daylight" opening sizes for Tip-Up and Steel Roll-Up type doors is the same as for Sectional type doors.

Certain assumptions have been made, i.e. :-

- 1) The opening sizes are standard.
- 2) The structure is level, square, plumb and true as the case may be.
- 3) For Sectional Doors, the door panel overlaps the opening by no more than 30 mm at the top and sides.

### Standard Opening Sizes

Single Size Doors :- ① x ② 2440 mm Wide x 2135 mm High

Double Size Doors :- ① x ② 4880 mm Wide x 2135 mm High

Caravan Height Doors :- The height of caravan doors will depend on whether a 5 Section or a 6 Section, ( or even more sections ), are to be used. A daylight opening height of 2560 mm is normally sufficient for caravans, Minibus and 4x4 vehicles with roof-racks.

### Minimum Space Required for Standard Size Sectional Doors:-

	Recommended Minimum	Absolute Minimum
Headroom ③ for automatic door	= 425 mm	375 mm
or ..... manual door	= 325 mm	290 mm
Nibs (both sides) ④	= 150 mm	120 mm
Centre Column ⑤	= 330 mm	240 mm
Backspace ⑥ for (automatic door)	= 3100 mm	N.A.
or ..... (manual door)	= 2650 mm	2450 mm
Overall garage width ⑦ for single size door	= 2740 mm	2680 mm
or ..... double size door	= 5180 mm	5120 mm

Take note of the minimums required ! If the space available is less than the minimums stated, special equipment will be required.

These dimensions will be affected by the design of the door, i.e. if the door is a 4 or 5 section door and also, each manufacturer may make the door sections a little wider or higher than the next one.

If no side access door is provided then extra equipment will have to be installed if the door is to be automated, ( e.g. an "Emergency Key-release Mechanism" ).

### Power Supply

A 3 Pin - 15 A - Single Phase socket outlet, 3 000 mm back from the opening and approximately 300 mm off the door centre-line is ideal.

This information booklet has been prepared by the Brano Industries / Brano Marketing Group and is distributed free of charge to members of the construction and door industries in the interest of promoting the development of safer and more reliable automatic garage doors.

# Examples of Problem Type Garages

## Resulting in Difficult and Consequently, Expensive Installations

### Garage Type 2

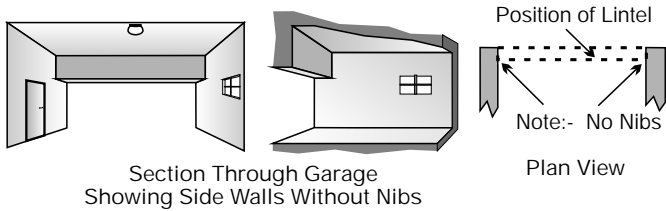

#### Type 2 Garage

The structure has an overhead Lintel providing headroom, but there are no Nibs. The side walls are flush with the "daylight" opening. It will necessary to create "false" nibs before doors can be installed.

### Garage Type 3

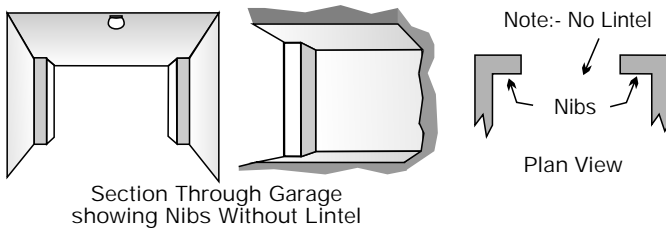

#### Type 3 Garage

There is no "headroom" ! The structure has Nibs at either side but no overhead Lintel. The ceiling is flush with the "daylight" opening. "Headroom" is an essential requirement for all "overhead" type garage doors. It will necessary to create the necessary headroom with a header panel before doors can be installed.

### Garage Type 4

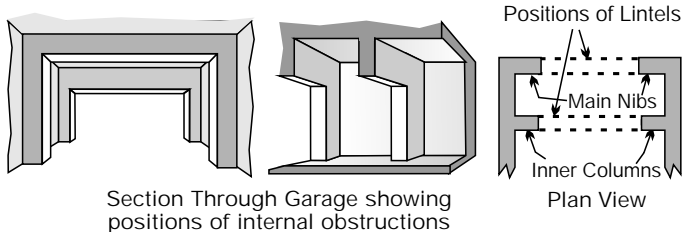

#### Type 4 Garage

"Headroom" and Nib space appear to be adequate, but behind the opening there is an obstructing column and overhead beam. Depending on the distance of the column from the "opening" the sizing of the garage door will have to be carefully considered.

"Side-room", (i.e. clear Nib space), is an essential requirement for all "jamb-mounted" type garage doors.

### Garage Type 5

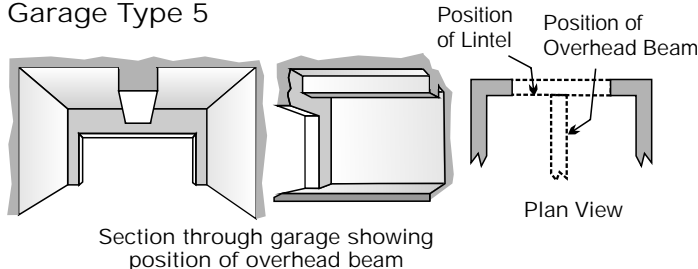

#### Type 5 Garage

"Headroom" and Nib space appear to be adequate, but behind the Lintel there is an obstructing beam overhead. Depending on the height of the beam above the floor, the sizing of the garage door will have to be carefully considered.

Such obstructions normally require the use of "special" hardware.

### Garage Type 6

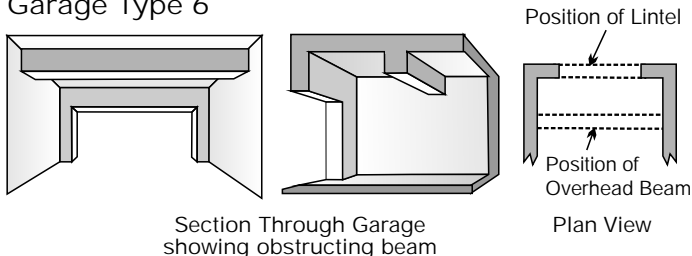

#### Type 6 Garage

"Headroom" and "Nib" space are adequate, but behind and parallel to the Lintel there is an obstructing overhead beam. This beam effectively reduces the headroom space available. Depending on the height of the beam above the floor and the distance from the opening, the sizing of the garage door will have to be carefully considered. Such obstructions normally require the use of "special" hardware.

### Garage Type 7

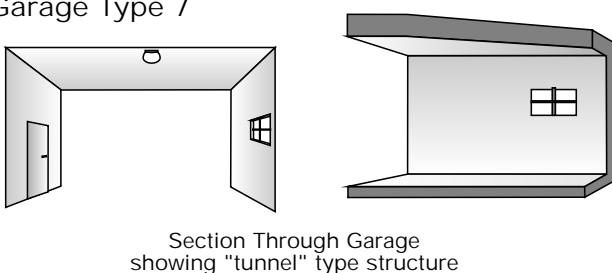

#### Type 7 Garage

There is no "Headroom" and no "Nib" space. The structure is like a "tunnel". Both the headroom and nib space must be created before a door can be installed. "Special" hardware and purpose made doors are often required for installations in this type of garage.

## Garage Type 8

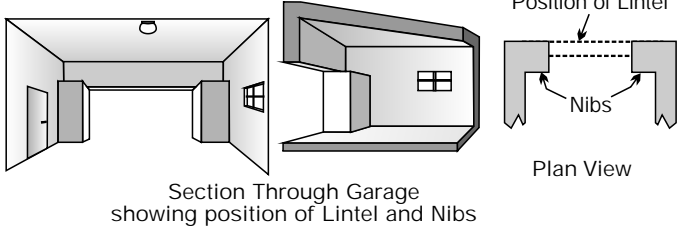

### Type 8 Garage

"Headroom" and "Nib" space are adequate, but the nibs extend beyond the inside face of the Lintel. This does present a problem for the installation of certain types of doors, notably "sectional" type doors. Ideally the lintel and nibs should be flush with each other. It may be necessary to provide a top "filler" piece to close the gap which will be left. Sectional Doors may require some special equipment and installation techniques.

## Garage Type 9

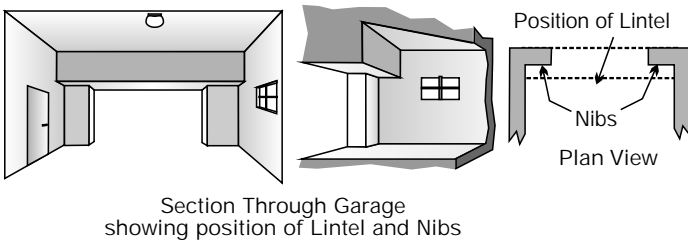

### Type 9 Garage

Similar to "Type 8" structures, "Type 9" garages have the lintel extending beyond the nibs. The Type 9 garage is a more difficult installation to contend with. If the lintel extends too far beyond the nib, the garage structure may have to be modified or else the hardware will have to be specially designed to suit the application. Sectional type doors in particular are affected by this type of garage structure and may require some special installation techniques.

## Garage Type 10 - ( A & B )

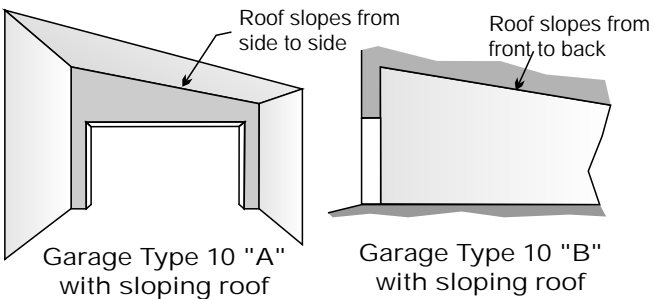

### Type "10 A" Garage

The roof slopes across the face of the door effectively reducing the "headroom" to what is available at the lowest side.

### Type "10 B" Garage

The roof in "Type 10 B" structures slopes either from the "front-to-back" as shown or from "back-to-front". In either case, the headroom available is reduced to whatever the minimum is, ( i.e. worst case ). You must consider the lowest side to be your effective "available headroom". Special installation techniques or hardware may be required.

## Important Information.

### What Size is the Vehicle ???

And what about the type and size of the vehicle using the garage ??? This most important question is very seldom asked, not only by architects and builders, but door dealers and installers as well. It is arguably the most important question that should be asked as the answer can affect every aspect of door selection imaginable, e.g. type, size and construction, as well as the most critical phase of the work, .....

..... the installation !!!!

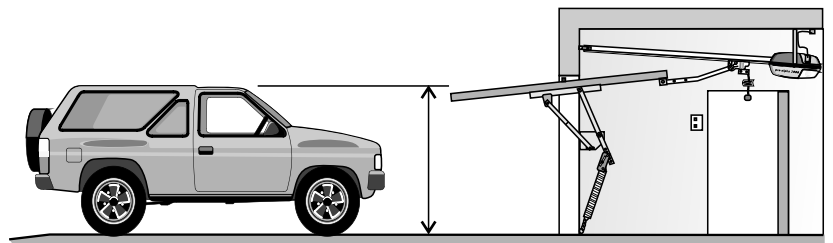

.... Make sure the vehicle will pass under the door !  
Specify the correct type of door to suit the application.

When advising clients on the selection of a suitable garage door, remember to ask the question ..... "what type of vehicle will be parked in this garage?"

### Door Duty Rating

The application of the door, i.e. the duty cycle it will be required to perform and the environment in which it will be operating are equally important. For normal domestic applications, a duty rating of 2 000 cycles per year is used. This equates to approximately 5 cycles per day. The design "life-expectancy" of components such as springs, lifting cables, rollers, cable drums and bearings is 10 000 cycles for domestic doors, which equates to 5 years of usage. After that period, they need to be replaced !!! When doors have to endure a higher traffic density of say 50 - 60 cycles per day, ( or approx 20 000 cycles per year ), then every component making up the door must be designed, constructed and selected accordingly to suit the application. Again ..... there are no short-cuts !!!

